

NATIONAL PHYSICAL LABORATORY, UK

TIME AND FREQUENCY STATUS REPORT, 1986

P B Coates, J E Gibbs, D J E Knight,
D S Sutcliffe and B R Swabey.

Division of Electrical Science
National Physical Laboratory Teddington,
Middlesex, TW11 OLW, UK

1. INTRODUCTION.

The National Physical Laboratory at Teddington, some 12 miles from the centre of London, was established in 1900 and with the immediate formation of an Observatory Department undertook to continue, along with other standards work, the testing of watches and chronometers previously calibrated at the Kew Observatory. With the formation of a frequency and time section in the 1920's, NPL began to contribute significantly to the development of increasingly accurate frequency and time standards and methods of dissemination.

2. HISTORY.

Well over a century ago, a time signal was being transmitted from the Royal Greenwich Observatory by direct line to Richmond Post Office and thence by two chronometers (early portable clocks!) to the Kew Observatory about one mile away. The Kew Observatory had been built privately in 1760 by King George III to observe a transit of Venus. In 1841, it was transferred to the auspices of the Royal Society and established as a centre for calibrating various measuring instruments, which, by 1884, included watches [1]. In 1889, a direct telegraphic connection existed between the two observatories and among the reference clocks in use at Kew was a Graham dead-beat regulator by French. From the records, it is known that a new second hand and electrical contacts fitted to this timepiece in 1896 proved unsatisfactory and were replaced in 1897 by Dent, a London clockmaker, probably best known for the manufacture of the clock mechanism of "Big Ben", the world-famous timekeeper at the Palace of Westminster. NPL was set up in 1900 in Bushy House on the present site, and the work undertaken at Kew Observatory transferred gradually to Teddington, including in 1912, the time section and the master clock by French. This clock still performs excellently at NPL, although not in the clock ensemble of the present time section but in the NPL Museum.

A rapid survey of the NPL Annual Reports reveals some interesting highlights: A valve-maintained tuning fork operated as a precision time standard with instabilities of around 3 parts in 10 000 per month. (1923). A travelling quartz resonator was assigned an identical frequency within one part in 1×10^5 by the (now) NBS, PTB and NPL and a BBC broadcast of standard modulation frequency derived from a tuning fork was used at NPL to drive a phonic wheel, (1929). In 1930 the Paris/London transmission of modulation frequency was received. Measurements agreed to within a few parts in a million. 1931 saw the start of a standard frequency broadcast from Teddington on 1.78 MHz, while 5MHz from Washington was received and compared within $1 \times$

10E8 in 1934. A quartz ring oscillator was stable to $1 \times 10E8$ in 1935. The first caesium atomic frequency standard for regular calibration of crystal oscillators to $1 \times 10E10$ was operational in May, 1955 [2]. The years 1955-1958 experienced the cooperative measurement with USNO to assign a value for Caesium in terms of Ephemeris Time. The result was the now well-known figure of 9 192 631 770 Hz [3]. The first time transfer by satellite was from Goonhilly, UK to Andover, US, in 1962 [4].

3. PRESENT STATUS.

3.1. Reference Clock System.

NPL currently maintains an ensemble of seven commercial caesium clocks, of these, four are fitted with option 004 and the remainder have standard tubes. The clocks are located in two separately controlled environments. Each has its own battery operated power supply and all important instruments in the installation can be powered from a back-up diesel generator should the need arise. One clock in each installation is equipped with a phase microstepper prior to the divider to 1 Hz. One such system is designated UTC(NPL), with the other acting as reserve. UTC(NPL) is maintained within approximately ± 5 microseconds of UTC with adjustments kept to an absolute minimum, the last being on MJD 45983 (1984 October 10).

3.2. Measurement Facility.

The measurement facility is divided into two sections. In the first, measurements are performed digitally on the clock ensemble and the received signals from time orientated transmissions such as GPS, LORAN C and TV, while the second, an analogue system, is dedicated to measuring the received phase of stable frequency transmissions from GBR on 16 kHz, MSF on 60 kHz and Droitwich on 200 kHz.

The automated digital measurement system comprises a separate coaxial switch and 2ns single shot timer in each room, controlled via the GPIB from a common computer with time-of-day clock, printer and disc store. Figure 1 illustrates the simplified arrangement. UTC(NPL) is connected permanently to the start terminal of each nanosecond timer. Beginning on the hour, each reference clock in the ensemble is connected in turn, by the switches, to the timer stop terminal. Visiting portable clocks and received time transmissions are also connected to the system. Each measurement is the mean of ten time difference readings and represents the delay of the selected clock or received time transmission relative to UTC(NPL). Individual cable delays from the reference location for UTC(NPL) have been measured and the transmission delay for LORAN C and TV assessed. These are accounted for in the software. The computed results, together with a time tag are printed each hour on hard copy and also transferred to floppy disc for permanent storage and subsequent analysis. Data for time scale research is currently transferred by floppy disc.

In the analogue measurement system, tracking receivers are used to establish the phase differences between the local reference frequency and the received signals. These are converted to DC voltages and applied to chart recorders. Experience has shown that phase differences taken from the chart by a skilled observer are more representative of the true performance of the received

signal than those performed automatically. Influence of the sky wave is likely to distort the trace and some visual averaging is often necessary. With more laboratories using high-stability reference sources, the demand for representative phase results is increasing. In an endeavour to improve the situation, a long-time-constant receiver has been purchased for MSF 60 kHz and this should provide more representative results.

3.3. Research Programme on Time Scale Algorithms.

In order to obtain a practical clock of maximum uniformity, it is necessary to apply predicted rate corrections and weighting factors to individual members of the clock ensemble. Various methods are possible and after considerable theoretical study of the time-scale problem, a high-speed algorithm due to Mr. G F Miller (formerly of NPL) has been adopted. To illustrate its rapidity, it suffices to remark that, implemented in Fortran on the ICL 2900 system at NPL, estimation of the statistical parameters of six clocks from 300 equally spaced sets of clock intercomparison data requires less than 1 second of CPU time. Homogeneity entails estimating the parameters afresh after each data-collection date. The new algorithm makes it possible for the first time to satisfy this requirement at an acceptable cost in computation.

The great speed and accuracy of this iterative algorithm are achieved by abandoning standard non-linear optimisation procedures in favour of a technique specifically tailored to the time-scale problem. To visualise the method, consider a set of p clocks interrogated at n equidistant dates. In particular, consider the p n -vectors that are contemporaneous finite time sequences of first differences of hypothetical indications of zero-rated correlates of the p clocks. These vectors form a basis for a p -dimensional euclidean space. It is assumed further that they are pairwise orthogonal, a condition which is approximated closely if the clocks are independent, but which need not be met exactly for the success of the method. Starting from a set of clock-variance estimates each equal to 1, and weights inversely proportional to these, the difference-vector for a provisional composite clock (PCC), with respect to the reference clock, is calculated as the weighted mean of the differences of the p basis vectors from the reference-clock vector. This yields immediately the difference-vectors for all the clocks with respect to the PCC and the corresponding variance-estimates. These variance estimates are the right members in a simultaneous system of p linear equations in the revised clock-variance estimates with coefficients that are quadratic functions of the weights. The revised clock-variance estimates yield updated weights with which to begin the next stage of iteration.

Convergence of the algorithm appears always to be rapid, but a delicate theoretical study is required to establish under what conditions this is true in general. Although we have referred above to equidistant data-collection dates, the method is applicable to unequally spaced dates and therefore to data acquired using non-geostationary satellites such as GPS. It can be extended to more elaborate statistical clock-models than those assumed in the initial trial. Further testing and modification is in progress, which includes the completion of a user-friendly operating system on the mainframe before transferring operations to a dedicated desk-top computer.

3.4. Dissemination.

The principal dissemination methods for frequency and time in the UK are via GBR 16 kHz, MSF 60 kHz, Droitwich 200 kHz, portable clock and British Telecom "Timeline" (speaking clock). Of these, MSF is a dedicated T and F service, the cost of which is borne by NPL.

The MSF system was started in 1950 with continuous transmissions on 2.5, 5 and 10 MHz intended to serve the UK and its approaches and Western Europe. Interference problems have been minimised by international cooperation in adopting suitable frequency offsets and modulation schedules, details of which appear in Report 267 of the CCIR Study Group 7 "Green Book" [6]. In recent years the number of users has fallen and the HF broadcasts from MSF are scheduled to cease on 1988 February 29. The 60 kHz transmissions will continue.

An initial one hour transmission on 60kHz was extended to 24 hours in 1966. Estimated radiated power on 60 kHz is 27 kW, with the carrier interrupted once per second. BCD (Binary Coded Decimal) pulse width modulated time information is inserted in the carrier breaks, to provide year, month, day-of-month, day-of-week, hour and minute information in the civil timescale currently in use. NPL provides the reference standards, time-code generators and measurement equipment at the MSF transmitter operated on behalf of NPL by British Telecom International (BTI) at Rugby some 100 km north of Teddington. The standards controlling the MSF system have been progressively updated from the original Essen ring 100 kHz crystal oscillators, through rubidium gas cell devices, to the current caesium beam frequency standard installed in 1976. Three links provide performance monitoring of the controlling standard: reception of received phase, an annual portable clock visit and regular time transfer-by-TV methods. The latter utilises common view measurements of a BBC transmitter at Sandy Heath, approximately 80 km from both Teddington and Rugby. Time transfer precision is better than 100 ns, which enables the controlling standard to be maintained generally within a few parts in 10^{13} of nominal.

Reception of the 60 kHz service in the UK is predominantly by ground wave, however, there is an ionospheric component which increases in magnitude at night and during the winter months. Analysis of the results from three laboratories located at distances of approximately 115, 140 and 195 km from the transmitter at Rugby shows variations during the winter months, in the 24 hour mean frequency deviation which increases progressively from 2 to about 10×10^{12} at the greatest distance. In the summer months, the daily variations reported at the three locations seldom exceeded 2×10^{12} . A particular role of MSF 60 is to provide traceability to NPL for laboratories accredited by the British Calibration Service (BCS) for precise frequency and time interval measurements.

The GBR 16 kHz transmitter at Rugby shares the frequency control provided for MSF 60. Until now, this transmitter has provided global coverage with stabilised carrier frequency and time signals introduced at selected times during the day. However, with the introduction of MSK (Minimum-Shift Keying) proposed for late 1986 or early 1987, the carrier will no longer be readily available as a frequency reference. Nevertheless it is possible within the receiver to double the carrier frequency to produce spectral lines at twice the upper and lower shift frequencies which, after suitable filtering, enables the phase-coherent carrier to be reconstituted [5]. It remains to be seen

whether any manufacturer will accept the challenge of producing such a device and so retain what has been the only terrestrial-based global coverage standard frequency transmission.

The BBC broadcast transmission on 200 kHz (due to change frequency to 198 kHz on 1988 February 01) continues to be an additional useful reference frequency for a large number of users. Carrier frequency is derived from a rubidium standard maintained within $\pm 2 \times 10^{-11}$ of the nominal frequency and is continuously monitored at NPL. Coverage in the north of the country is now improved by additional low-power transmitters sited at Burghead and Westerglen. These are controlled by independent rubidium oscillators which, because of the distance from NPL, are impossible to monitor at NPL, so traceability to national standards via these transmitters is not available. They are however, maintained within $\pm 2 \times 10^{-11}$ of nominal by the BBC. Details of these and other national standard frequency and time services are contained in the CCIR "Green Book" [6].

For those requiring particularly precise synchronisation to time standards, NPL offers a time transfer by portable clock facility. A charge is made for this service which is capable of a time transfer accuracy of better than 50 ns.

A major source of lower grade time transfer is offered by the British Telecom "Timeline" or speaking clock. The two independent quartz controlled systems providing this national service are synchronised daily by the NPL caesium clock at Rugby. "Timeline" is a popular facility accessed by about two-thirds of a million callers each day.

3.5. International Time Coordination.

For many years, LORAN C from Sylt (7970-W) in the Norwegian Sea chain has been the mainstay of the time link from NPL to the Bureau International de l'Heure (BIH). Regular measurements are made on the automated measurement facility and transmitted to the BIH via the General Electric MK 111.

Since 1986 February 01, these have been supplemented by data from the Global Positioning System (GPS). NPL has three independent receivers. The antenna position of the prime receiver has been determined using the internal navigation programme and recently, by conventional survey techniques, by the Survey Squadron of the Territorial Army. When translated to the GPS coordinate system, WGS 72, the two methods agree to within 4 m longitude and 2.5 m latitude. In an endeavour to resolve the discrepancy between various methods of time transfer, the National Bureau of Standards (NBS) in conjunction with the BIH, organised a "travelling" GPS receiver evaluation. A discrepancy of approximately 30 ns needs identification and will be eliminated from the prime receiver when the source has been discovered.

As part of the assessment procedure for a BCS laboratory, it is necessary to demonstrate appropriate traceability to National Standards. In the case of a new laboratory recently established in Hong Kong, GPS provided an excellent time link (and hence frequency) to satisfy the assessors.

The T & F facility at Teddington includes two satellite earth stations. The first covers the 4-6 GHz band using a 10 m dish with Cassegrain configuration, GaAs FET low noise amplifier and G/T figure of merit of 29.5 dB/K. As part of

a metrology exchange programme with the USSR, some initial experiments have been conducted in receiving and measuring the arrival time of a reference pulse interposed on line six of the Gorizont satellites. Satisfactory reception and measurement of the westerly satellite pulse has been achieved but poor S/N characteristics prevent measurement of that from the easterly satellite. Unfortunately, accurate positional coordinates are at present, only available for the latter of these two satellites, so the experiment has been temporarily abandoned.

The second earth terminal covers 11-14 GHz. In this installation, a 3 m antenna is coupled to a GaAs FET LNA. G/T is 22.9 dB/K. The system was used extensively during 1982/3 in the experiment "Time Synchronisation via OTS-2" [7]. In this exercise four member countries of the European Community intercompared time scales by three methods: viz. satellite TV, LORAN C and portable clock. The results showed that, provided the satellite coordinates and earth terminal delays were known with sufficient accuracy, the inherent uncertainty in time comparison via the one-way, common view method can be less than 20 ns.

3.6. Research Programme on Time and Frequency Standards.

At the beginning of 1983, a survey of the various techniques showing potential as future standards of time was carried out within the time and frequency section at NPL. Two areas were identified as being of particular interest. Ion trapping techniques are now being studied within the Division of Mechanical and Optical Metrology, primarily as possible wavelength standards. The second, improved atomic methods, now form part of the Division of Electrical Science.

The investigation of the potential for ultra-stable frequency standards offered by laser cooled trapped ions (both in microwave and optical regions,) has been conducted within the stabilized laser group at NPL. Preliminary work has drawn on the expertise with dye lasers for cooling. The UHV technology necessary for the construction and processing of ion traps has been established, and initial experiments conducted on Mg^+ ions contained within a Penning trap. Laser cooling of these ions was first demonstrated two years ago using a 560 nm ring dye laser radiation doubled to 280 nm in an AD P crystal. Measured linewidths of the 280 nm fluorescence emitted indicate cooled temperatures around 100 mK. Subsequent research has determined the characteristics of the various trap parameters, including oscillation frequencies, storage times and cloud densities.

The limitation of Mg^+ from the viewpoint of a potential trapped ion is the lack of a suitable "clock" transition of narrow enough natural linewidth. Currently, consideration is being given to other possible candidates, such as Yb^+ , which do have suitable narrow transitions. In parallel with this, a narrow linewidth ring dye laser system is being developed to probe the trapped ion.

Improvements to atomic beam standards may be achieved by the application of optical pumping to state selection and detection, and by reducing the average beam velocity with laser cooling. It was decided to investigate these possibilities with caesium beams, as this element possesses a combination of practical advantages. The application of these techniques to elements with higher frequency transitions, and therefore possibly higher Q-values might follow at a later stage. In both cases, laser diodes form convenient sources

of radiation. They are physically small, require little power, and are capable of stable operation over very long periods. Most of the practical work to date has been with the application of these devices.

Although index-guided laser diodes appear to be the natural choice for these applications, they possess a number of disadvantages. First, they are difficult to manufacture, and as a result are not readily available commercially. Typical delivery times for diodes specified to operate at wavelengths close to the caesium resonance wavelength of 852 nm are between 6 and 12 months. Second, there appears to be a problem with the long-term stability of these devices; several groups have reported either drifts in the wavelength or a gradual degradation in the output power. In addition, index-guided diodes are very sensitive to small amounts of optical feedback, and this can significantly degrade the signal-to-noise level achieved.

We have therefore studied the characteristics of gain-guided laser diodes, which are more easily manufactured and readily available. For optical pumping with caesium, we require an output level around 0.1-0.5 mW, with a long-term stability and a bandwidth of 5-10 MHz to match the natural bandwidth of the resonance transition. As shown in Figure 3, the output from a gain-guided diode alone has a complex mode structure, consisting of many modes about 0.3 nm apart, each with a bandwidth of about 5 GHz. It should be noted that both the position and the shape of the mode distribution are dependent upon the temperature of the diode and the current flowing through it.

The mode distribution may be modified by placing the diode in an external optical cavity. First, a semi-reflecting mirror is placed at a distance of around 200 mm from the emitting facet of the diode. When the mirror is adjusted to be precisely normal to the collimated beam from the diode, strong optical feedback is obtained. This increases the power emitted by the diode at a given current, and reduces the width of the mode distribution, as shown in Figure 4. The bandwidth of the individual modes is, however, increased somewhat, to around 10 GHz. With the inclusion of a thin (100 μ m) air-spaced etalon, with a free spectral range of 3.7 nm, a single mode at the required wavelength may be selected (Figure 5), although some transmission of adjacent modes and others at intervals of 3.7 nm may also be observed. The addition of a thick etalon, with a free spectral range of 10 GHz, not only cleans up the mode structure, but reduces the bandwidth of the resulting single mode, measured with a confocal Fabry-Perot spectrum analyser, to around 5 MHz (Figure 6). Both etalons are tilted away from the normal to avoid unwanted feedback into the diode.

The resulting system, though complex, has a number of advantages. As the laser diode current, or its temperature, is varied, the output frequency remains virtually constant until it "hops" to the adjacent thick etalon mode 10 GHz away. The requirements on the diode current and temperature stability are therefore much reduced, to about 1% in current and 0.2 K in temperature. The frequency may be tuned by controlling the plate separation of the thick etalon with piezo-electric translators (PZTs). Alternatively, the voltage input to these may be used to lock the output frequency to one of the caesium resonance transitions, using a feedback signal from the atomic beam or a separate caesium-filled cell. To date, a number of different designs of cavity-stabilised diode sources have been tested. Two are now under construction, to enable linewidth and long-term stability tests to be carried out.

Recent work [8], [9], has shown that substantial slowing of beams of sodium and caesium atoms may be achieved without unduly complex experimental systems. There are, however, a number of problems in the application of these techniques to the design of atomic clocks. The natural divergence of the beam is accentuated by the cooling process, so that the signal amplitude is reduced unless larger beam diameters are permitted. Also, the motion of slow atoms is appreciably affected by gravity. Atoms with a horizontal velocity of 30 m.s⁻¹ will fall about 5 mm in passing through a Ramsey cavity 1 m long. The effect is particularly important with a broad velocity distribution, as it reintroduces the problems of velocity-dependent trajectories which limit the performance of conventional caesium beam standards. With a cooled beam, however, the velocity distribution of the slow atoms is narrow (Figure 7), and the effect may be used to separate the slow atoms from those unaffected by the laser cooling. It may, of course, be avoided by operating the beam vertically, but this requires more careful magnetic screening to eliminate the effects of the earth's magnetic field.

Finally, it should be noted that, in existing methods of laser cooling, the laser beam matches geometrically the atomic beam, but is, of course, propagating in the opposite direction. The cooled atoms are therefore not readily available for feeding into a clock. Work is in progress at NPL on a laser beam geometry which is intended not only to cool the atomic beam, but to reduce the lateral divergence, and to leave the exit region uncluttered with optical components. An additional advantage is that the laser beam frequency does not require chirping to match the Doppler shift of the slowing atoms.

3.7. Laser Frequency Measurement.

The NPL laser frequency measurement work has recently been combined with the Time and Frequency Section. In the immediate future, the first concern will remain the dissemination of laser frequency standards [11], measurement having been extended to 3.39 μ m [12] but not yet to 576 nm [13]. In the longer term the techniques may provide a means of linking to the timescale [14] high quality frequency standards at infrared or higher frequencies, such as the heavy molecules in gas cells [15] or from systems held in electromagnetic traps [16].

4. FUTURE PLANS

4.1. Reference Clock System.

Looking ahead to potential single nanosecond precision satellite time transfers, attention is being given to improving the short-term stability of the reference clock system. Low-jitter dividers are being obtained and these will be introduced into the UTC(NPL) chain. We also hope to purchase a passive H maser for installation adjacent to one section of the reference clock ensemble where the temperature control is being upgraded to achieve ± 0.2 K over the year.

4.2/3. Measurement Facility/Time Scales.

The long-term plan in this area is to combine these two computer-operated functions. A comprehensive computer and hard disc storage medium have been acquired and it is anticipated that this combination will control the

measurement system of Figure 1 and also perform the time scale algorithm computation necessary to produce a real-time practical clock.

4.4. Dissemination.

NPL endeavours to monitor the users of the MSF service to ascertain their views and determine future requirements. It is also necessary to consider the cost-effectiveness of the national T & F distribution system. This is a difficult task, as other SFT operators will testify. In pursuance of this policy, it is proposed to withdraw the MSF HF series of broadcasts on 1988 February 29. MSF 60 will continue for the foreseeable future and an extensive series of upgrades for the MSF equipment at the Rugby Radio Station is currently in progress. Improvements are being made to the time-code generation equipment (making full use of integrated circuits to replace the discrete components currently in use in a number of areas) and also in the measurement and data handling areas. It is proposed to access the measurement equipment at Rugby via the PSS (Packet Switch Stream). This will facilitate closer steering of the reference standards and allow the standards at Rugby to contribute data to the NPL ensemble.

There is potential in LF transmissions other than MSF 60 kHz. An investigation is proposed into closer phase control, possibly linked to MSF and for phase modulated time information to be applied to an existing LF wide-coverage transmitter. NPL is also aware of the need to consider dissemination systems for the next century. These will certainly include a measure of satellite services, possibly using a time reference pulse or code inserted on unused lines of a DBS (Direct Broadcast Service) TV transmission. More care applied to station keeping and/or appropriate methods of ranging will be required to obtain the satellite coordinates necessary for corrections to be given with the appropriate precision.

4.5 International Time Coordination.

There is no doubt that the requirements for international time coordination will increase with the availability of improved reference standards and the evolution of more applications requiring precise time. NPL is preparing for the forthcoming international collaborative experiment using the PRN (Pseudo Random Noise) technique reported by Hartl et al. [8]. All equipment is currently to hand, including the MITREX Modem, and modifications have already been made on the geometry of the 3 m antenna by reconfiguring to Cassegrain optics and installing a transmit facility. Low power tests will commence in the new year. Unfortunately, the source of UTC(NPL) is remote from the earth station. Coaxial cables have been laid to transmit and monitor UTC(NPL) at the remote site, some 1 km distant. A long-term series of measurements will be inaugurated to validate this technique.

5. SUMMARY.

Current activity in the PTTI area at NPL UK has been presented. NPL maintains a group of caesium beam reference standards, continuously intercompared by an automated measurement system. Research into time scale algorithms and improved reference standards using optical pumping is progressing. UTC(NPL) is disseminated in the UK by the MSF service from the Rugby Radio Station. Internationally, NPL participates in an extensive time coordination programme using LORAN C and GPS. NPL clock data is contributed to BIH. An experiment has

been initiated to improve international coordination to the single nanosecond level currently demanded.

ACKNOWLEDGEMENTS

We are grateful to Dr. P Gill for contributing details of the work of the Division of Mechanical and Optical Metrology, to this report.

REFERENCES.

- [1]. WHITE, T.E , "The Testing and Certification of Watches at the Kew Observatory and National Physical Laboratory, 1884 to 1978". Horological Journal, pp15-17, August 1984.
- [2]. Essen, L and Parry, J V L, "The Caesium Resonator as a Standard of Frequency and Time". Phil. Trans. Roy. Soc. 250, pp 45-69, 1957.
- [3]. Markowitz, W, Hall, R, Essen, L and Parry, J, "Frequency of Caesium in Terms of Ephemeris Time". Phys. Rev. Lett, 1, pp 105-107, 1958.
- [4]. Steele, J McA, et al. "Telstar Time Synchronization". IEEE Trans. Instr. & Meas. IM-13, 4, pp 164-170, 1964.
- [5]. Steele, J McA, "Time and Frequency Reference in the UK - Dissemination, Use and Future Development". British Electromagnetic Measurements Conference, NPL. pp 12/3, 1985.
- [6]. Recommendations and Reports of the CCIR, Vol.VIII, "Standard Frequencies and Time Signals", ITU, Geneva. (New edition in press).
- [7]. de Jong, G, Kaarls, R, Kirchner, D, and Ressler, H, "Time Comparison via OTS-2", Proc 13th PTTI Applications and Planning Meeting, pp 347-369, 1981.
- [8]. Philips, W D, Prodan, J V, and Metcalf, H J, "Laser Cooling and Electromagnetic Trapping of Neutral Atoms", J. Opt. Soc. Amer. B2, pp 1751-1767, 1985.
- [9]. Watts, R N and Wieman, C E, "Manipulating Atomic Velocities Using Diode Lasers", Opt. Lett. 11, pp 291-293, 1986
- [10]. Hartl et al, "Spread Spectrum Time Transfer Experiment via Intelsat". Proc. 15th PTTI Applications and Planning Meeting, pp 331-356, 1983.
- [11]. Knight, D J E, "A Tabulation of Absolute Laser-Frequency". Metrologia, 22 (3), pp 251-257, 1986.
- [12]. Knight, D J E, Edwards, G J, Pearce, P R, and Cross, N R, "Measurement of the Frequency of the 3.39 μm Methane-Stabilised Laser to ± 3 Parts in 10^{11} ". IEE Trans. Instr. & Meas. IM-29 (4), pp 257-264, 1980

- [13]. Knight. D J E, Edwards. G E, Pearce. P R, Pharaoh. K I, Barwood. G P, Cross. N R, Fan Xi-Sheng and Golby. J A, "Progress in an Experiment to Measure the Frequency of an I2-Stabilized Dye Laser at 520 THz (576 nm)". Sov. J. Quant. Electron. 15 (10), pp 1374-1377, 1985.
- [14]. Chebotayev, J, "Optical Time Scale". J. de Physique Colloque C8, supplement to 42, (12), pp C8-505 - C8-512, 1981.
- [15]. Clairon, A, Dahmani, B, Filimon, A, and Rutman, J, "Precise Frequency Measurements of CO₂/OsO₄ and He/CH₄ Stabilized Lasers". IEEE Trans. Instr. & Meas., IM-34 (2) pp 265-268.
- [16]. Thompson, R, Barwood, G P, and Gill, P, Laser Cooling of Magnesium Ions confined in a Penning Trap". Optica Acta, 33 (4), pp 535-543.

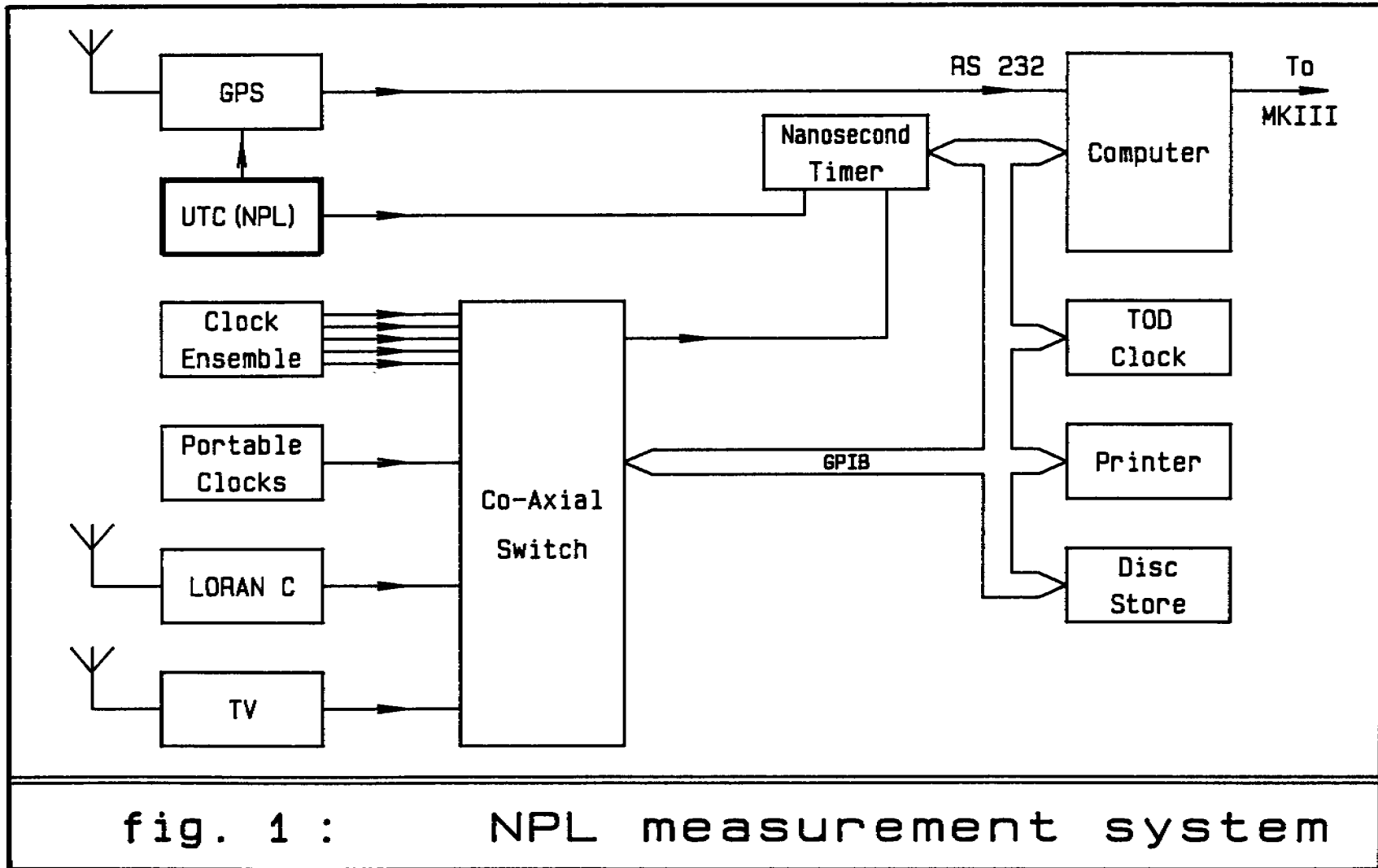

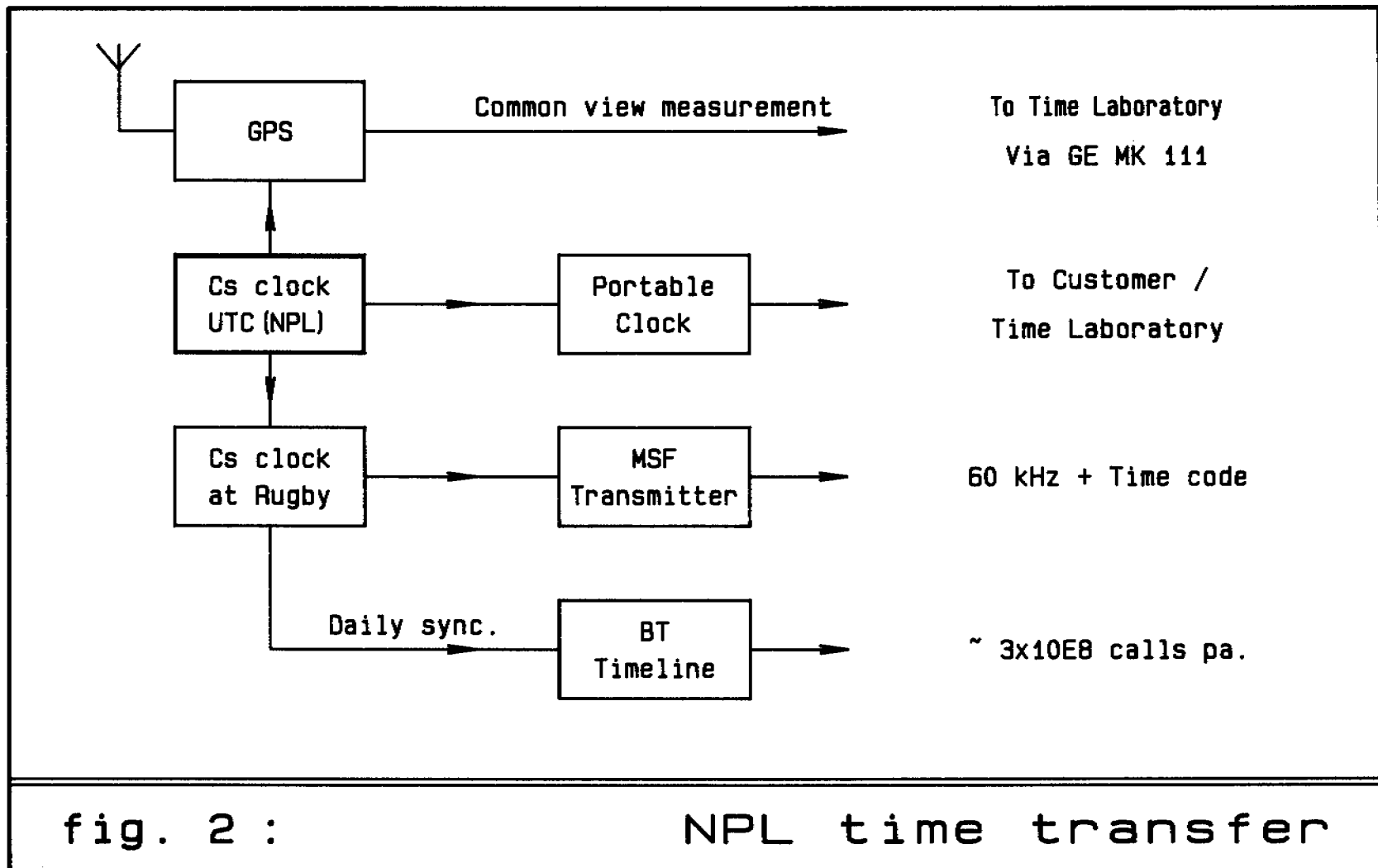

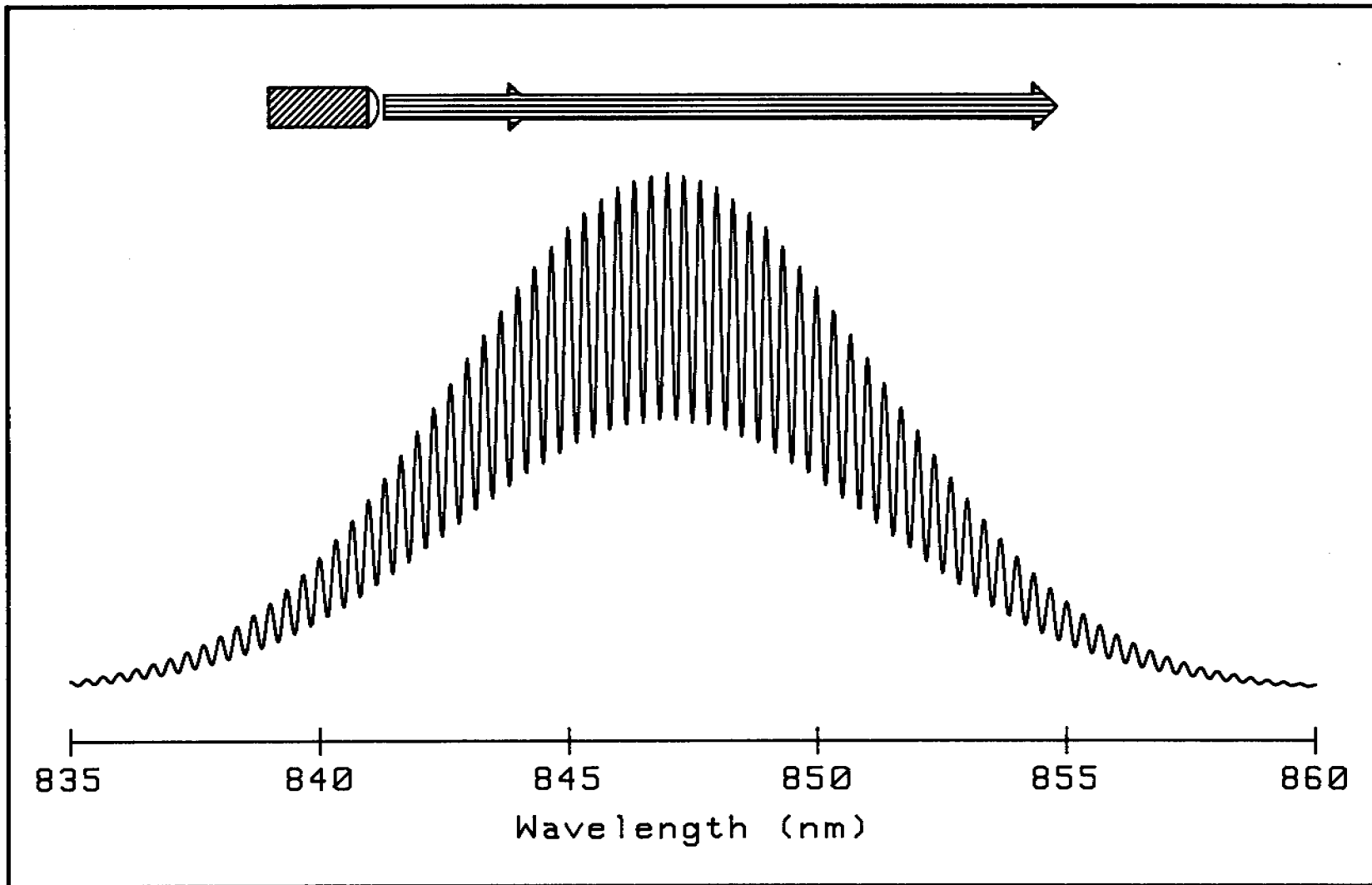

fig. 3 : Laser diode mode distribution

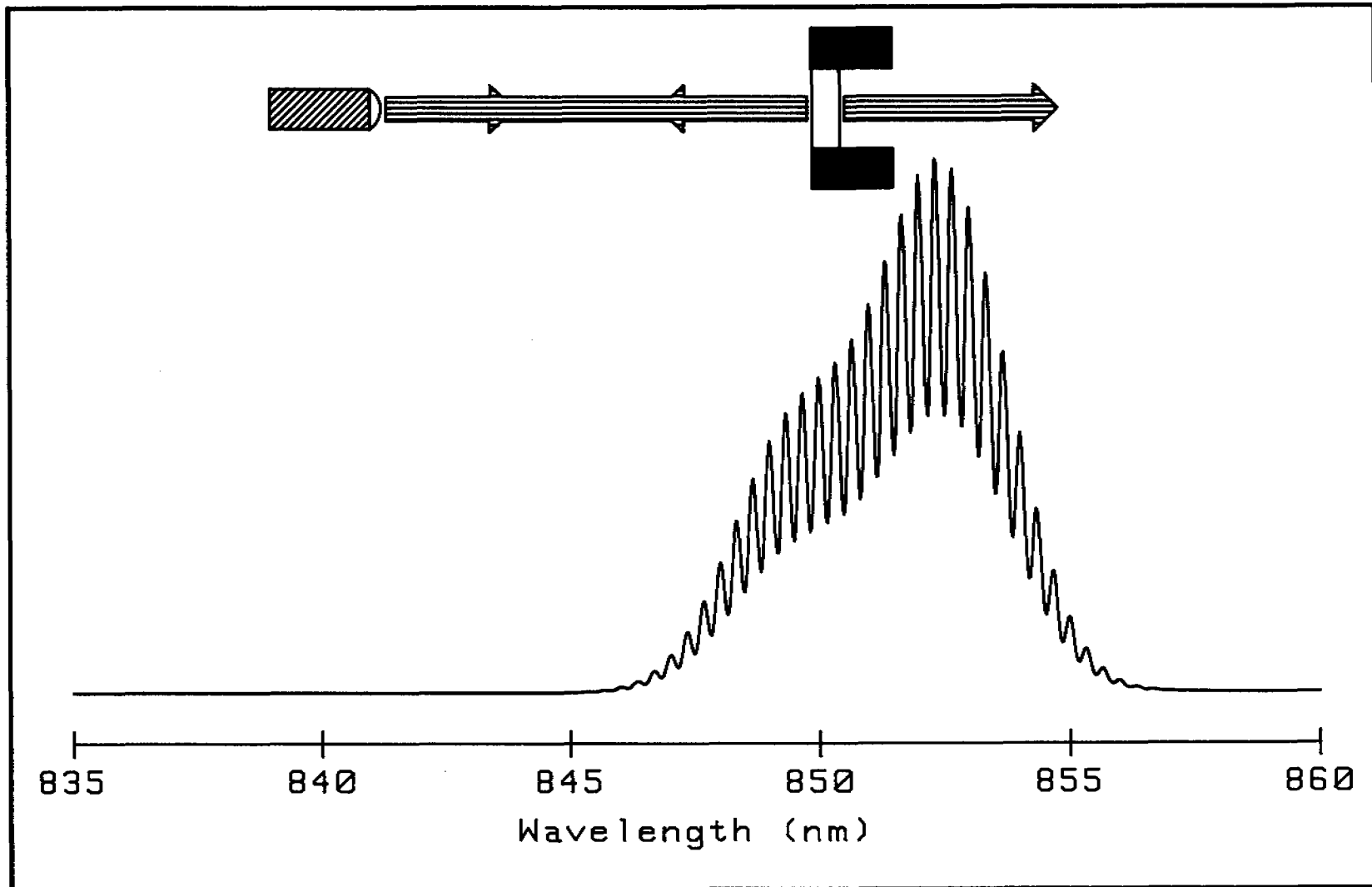

fig. 4 : Formation of optical cavity

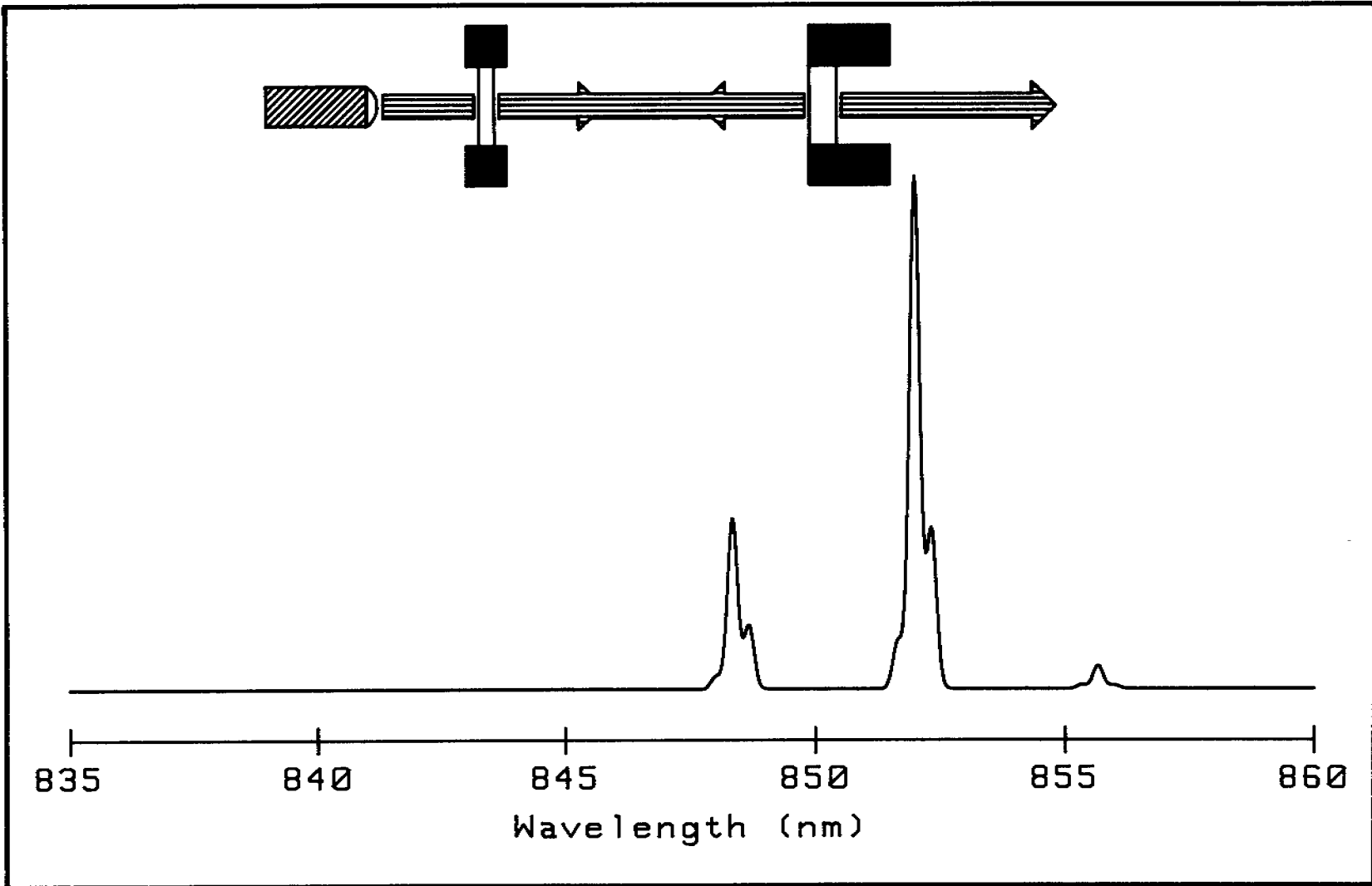

fig. 5 : Selection of laser diode mode

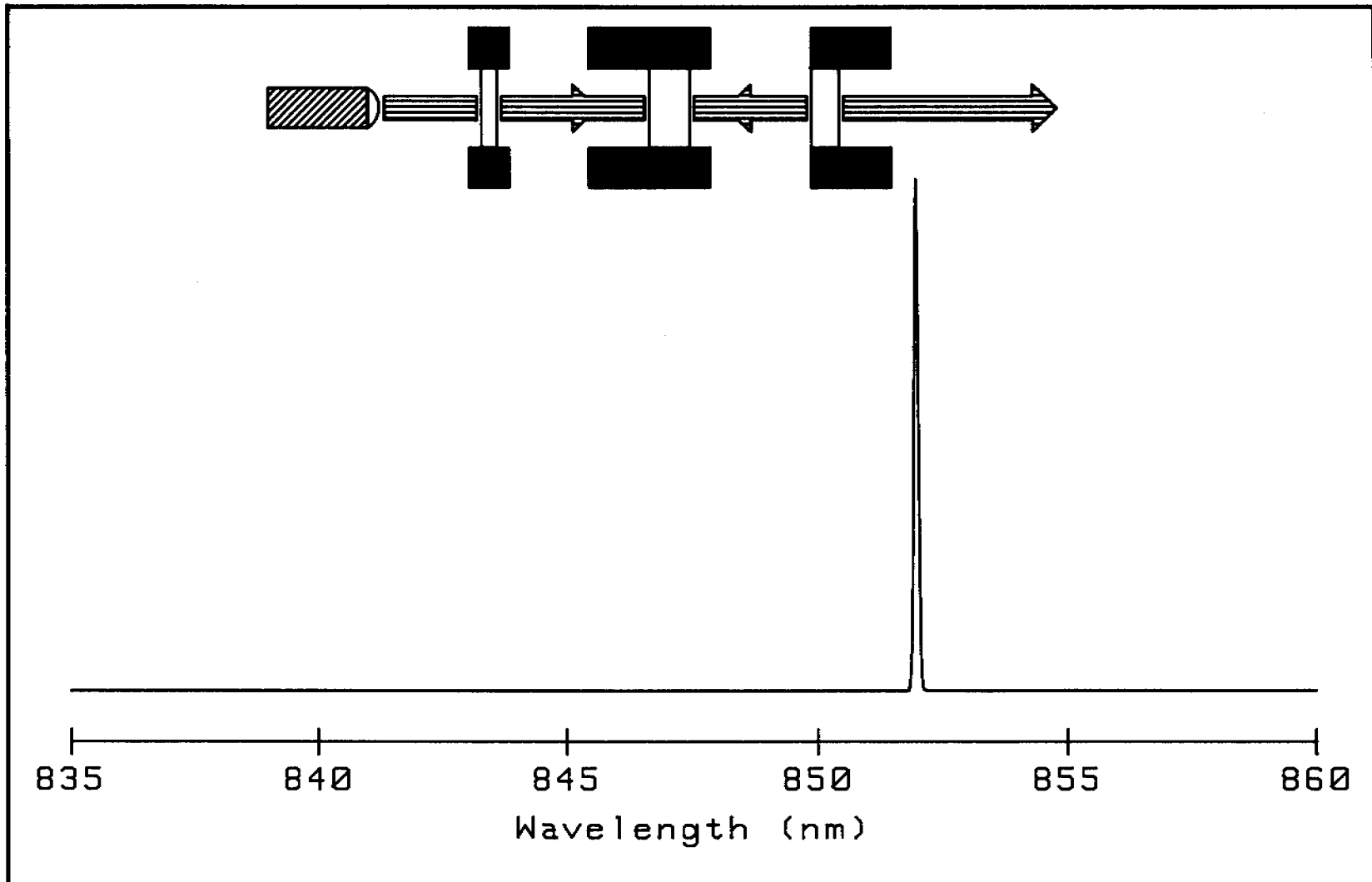

fig. 6 : Narrow bandwidth single mode

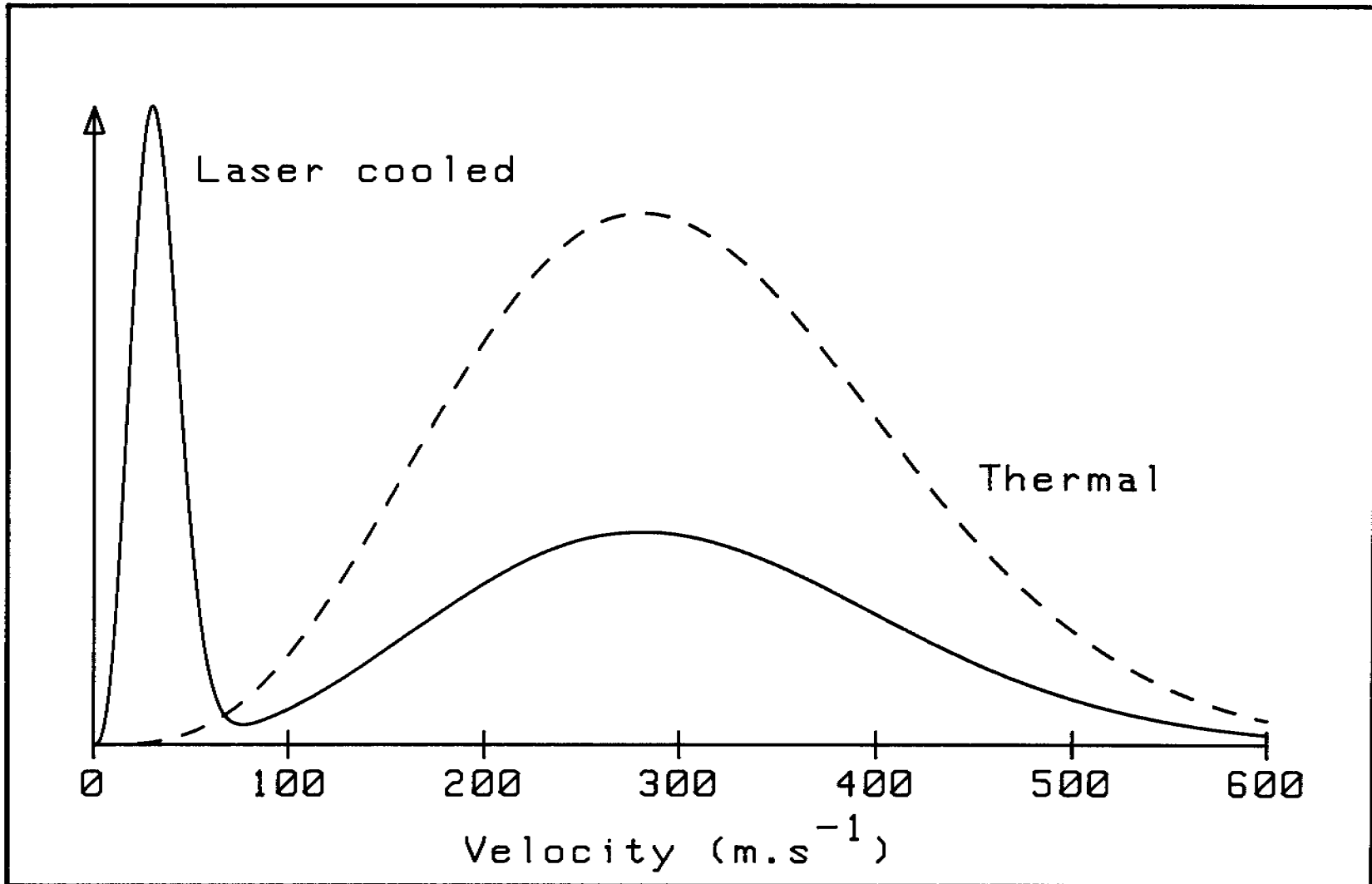

fig. 7 : Atomic velocity distributions